

Characteristics

2-way flow control valves series GFG2 are used to provide pressure compensated flow. The valve design compensates temperature variations to a certain extent. The GFG is optionally equipped with a built-in check valve for the return flow.

Design

The 2-way flow control valves are used with a triangular flow restrictor and a subsequent pressure compensator. The setting of the flow rate can be locked by a cylinder lock in the adjusting knob against unauthorized adjustment (option S).

Function

The fluid enters through port A through the flow restrictor. Downstream of the flow restrictor the pressure compensator is located. The control edges are provided by four radial bores in the poppet, which are fully open to port B in the neutral position.

Optionally the flow from A to B can be blocked by external pilot pressure applied to port P (option X). This can be used to avoid unintended initial movements of actuators. The flow adjustment is done via the hand knob with an adjusting angle knob of 270°.

Features

- Flow rate independent of pressure and temperature
- Available for 7 different flow rates
- Good fine adjustment
- External port (P) to block flow from A to B
- Optional reverse flow check valve
- Turn knob with cylinder lock (option S)

Note

Rectifier plate and subplates see 'Accessories' at the end of this chapter.

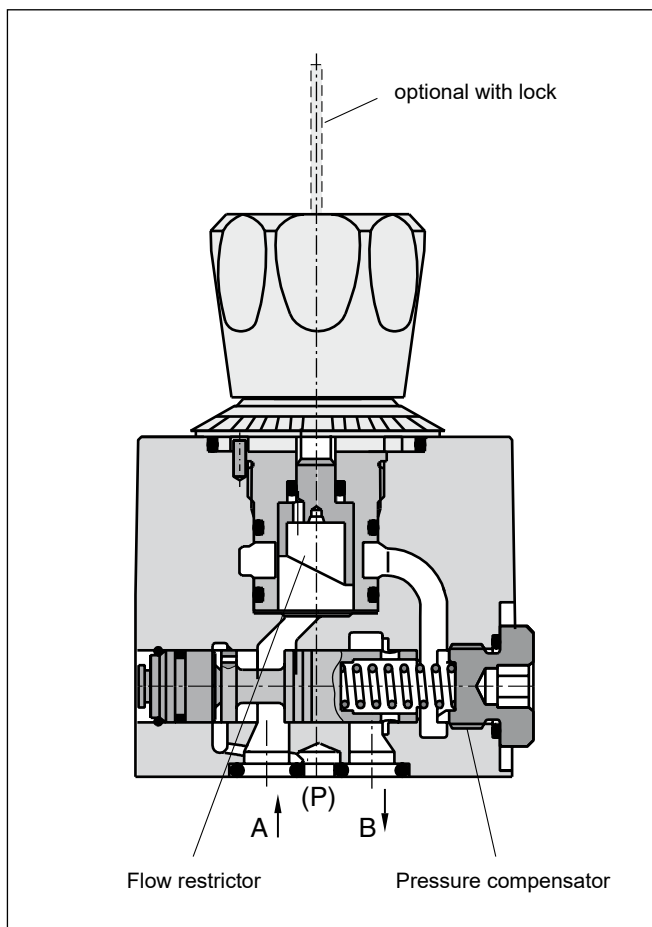
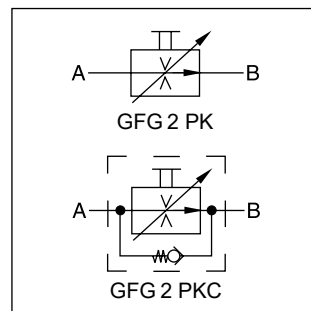

5

Ordering code

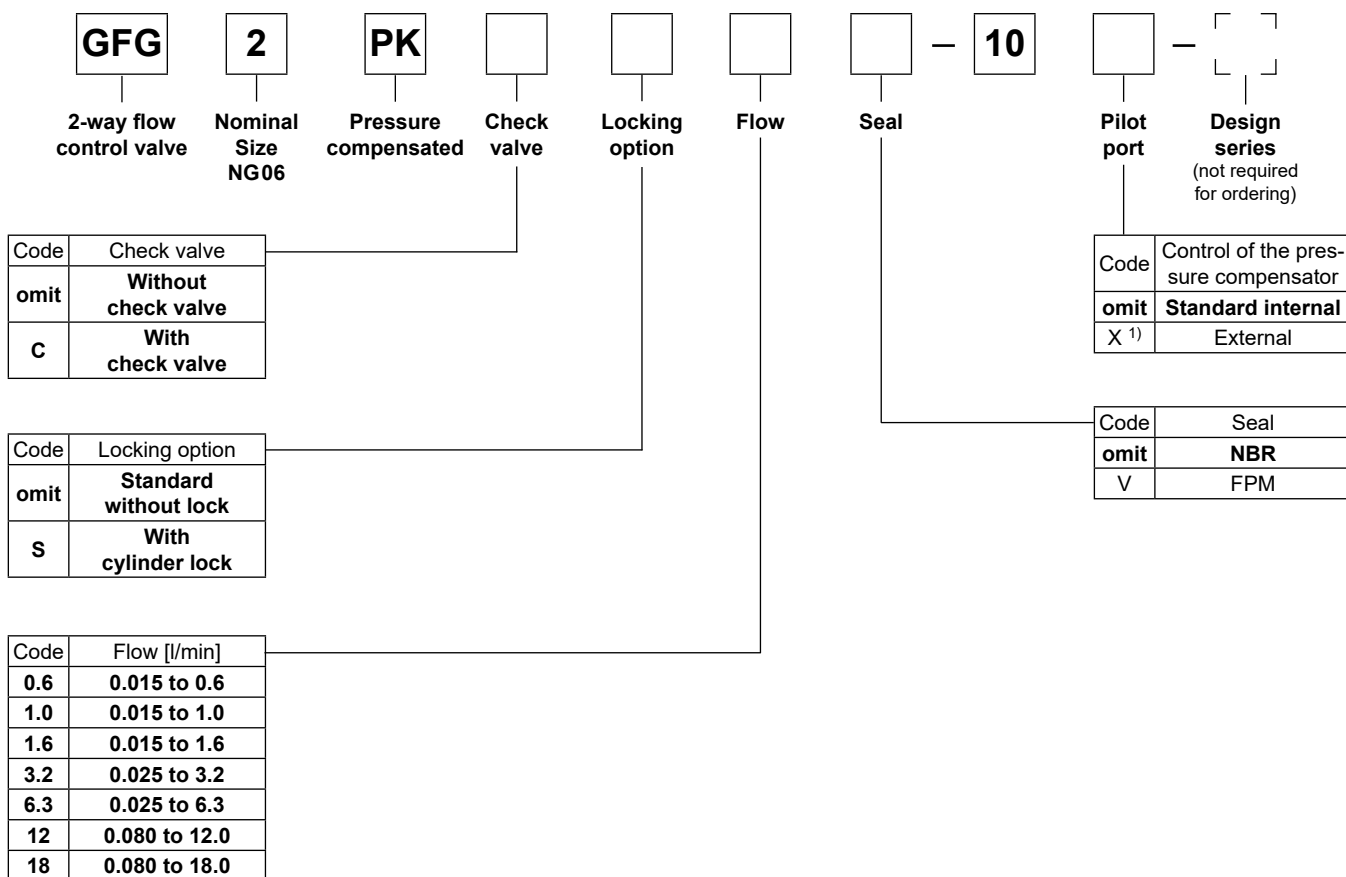

Bold letters = Short-term availability

¹⁾ Only in combination with integrated check valve.

Technical data

Design	Orifice, infinitely variable, pressure-compensated
Actuator	Manual flow rate adjustment
Mounting type	ISO 6263 code: ISO 6263-AB-03-4-B
Mounting position	unrestricted
MTTF _D value	[years] 150
Weight	[kg] 1.1 (without subplate)
Ambient temperature	[°C] -20...+60
Fluid	Hydraulic oil according to DIN 51524
Fluid temperature	[°C] -20...+70 (NBR: -25...+70)
Viscosity, permitted	[cSt] / [mm ² /s] 20 ... 400
recommended	[cSt] / [mm ² /s] 30 ... 80
Filtering	ISO 4406 (1999); 18/16/13
Min. pressure difference	[bar] 5 (GFG*1.6/3.2), 8.5 (GFG*6.3/12/18)
Operating pressure	[bar] A; B = 315, P = 5 (GFG*, GFG*C), A, B, P = 160 (GFG*X)
Effect of pressure on Q _{max} at p = 160 bar	[%] ± 2 (GFG*1.6/3.2/6.3/12), ± 2.5 (GFG*18)
Flow direction	
A → B	Flow control function
B → A	Throttle function or free flow through check valve

Performance curves

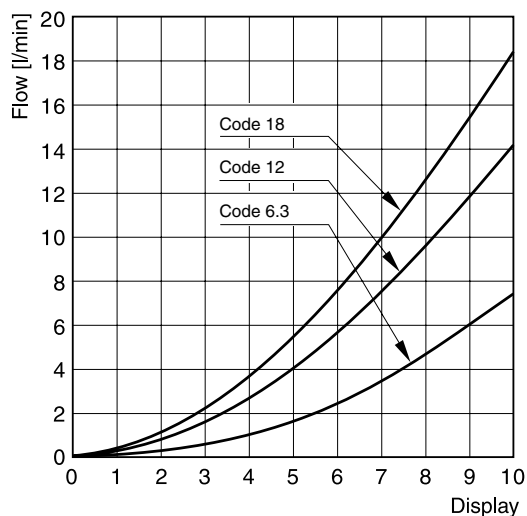
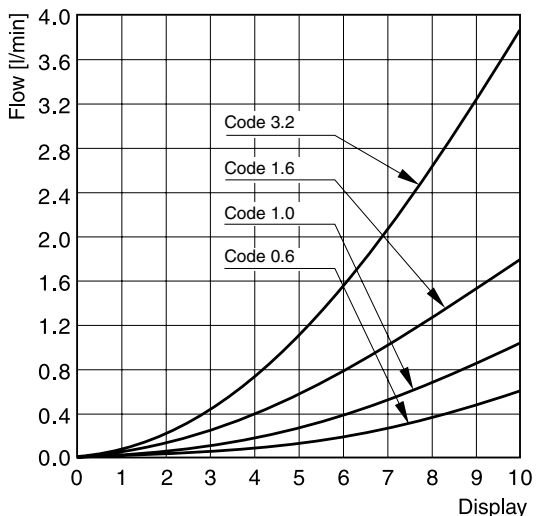

All characteristic curves measured with HLP46 at 50 °C.

Changes in pressure cause a change of pre-set flow rate. Flow rate deviations at Q_{max} : $\pm 2\%$

Dimensions

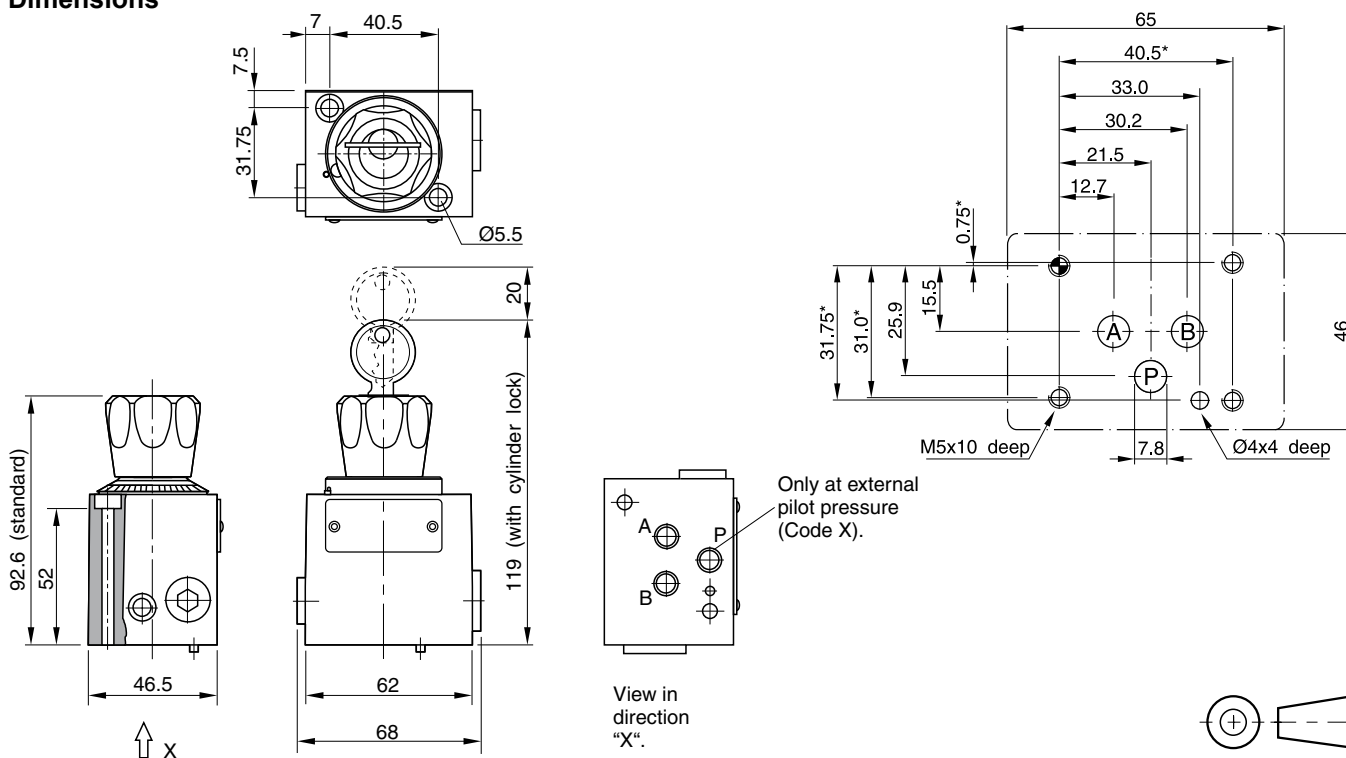

Bolt kits (Cylinder head ISO 4762-12.9 not included)

Nominal size Valve	Valve model	Quantity	Tightening torque [Nm]	Valve without rectifier plate Dimensions	Order No.	Valve with rectifier plate Dimensions	Order No.
NG06	GFG2	2	7.6 Nm	2x M5x60	BK380	2x M5x100	BK466

O-rings for sealing the connecting surface

Nominal size Valve	Valve model	Ports	Dimensions Ø-inner x cord thickness	Quantity	Seal kits	
					NBR	FPM
NG06	GFG2	A and B	9.25 x 1.78	3	SK-GFG2	SK-GFG2 FPM

Sandwich rectifier plate

If a 2-way flow control valve is used in combination with a rectifier plate the valve can be used for meter-in and meter-out flow control of an actuator.

Design

The intermediate rectifier plate is designed with 4 identical, symmetrically arranged check valves. Thus the differential pressure is the same in both flow directions.

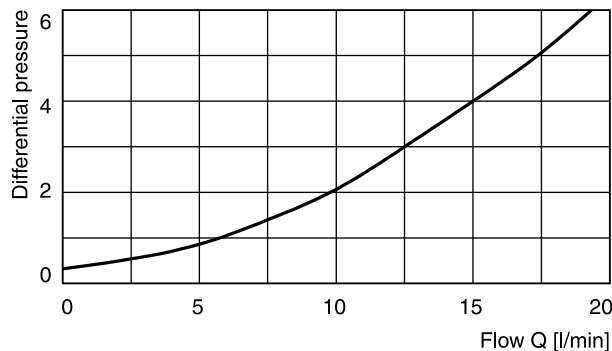
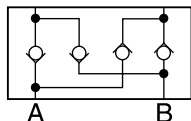

Measured with HLP46 at 50 °C.

Dimensions

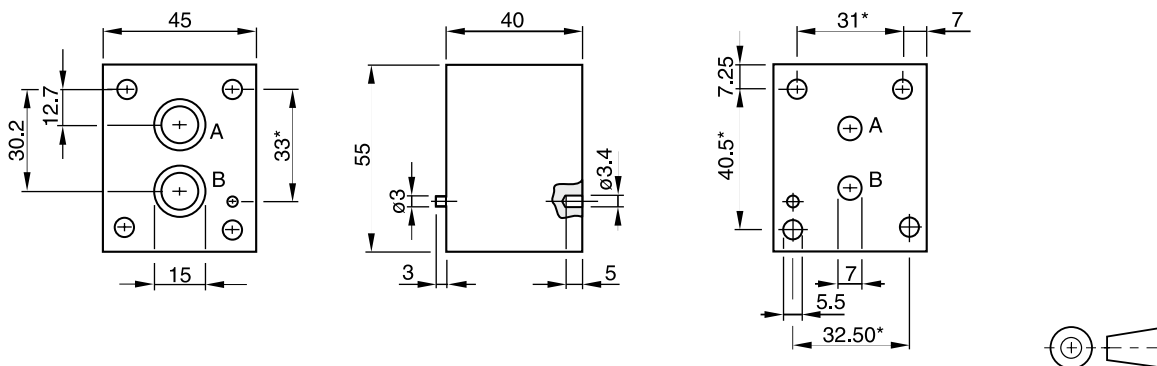

Dimension tolerances
 * : ± 0.1 mm
 others : ± 0.2 mm
 holes and silhouette of valve body : untoleranced dimension

Ordering code: HR OA 06 C

O-ring for sealing the connecting surface

Connections	Dimensions	required units
A, B	12 x 1.5	2

Subplates ¹⁾

Ordering code	
SPD 22 B 910	P, A, B and T = G1/4
SPD 23 B 910	P, A, B and T = G1/8

¹⁾ Details see chapter 12, series SPD.